

HALOGEN FREE

REVISIONS

REV	DESCRIPTION	DWN	DATE
B	MODIFY DATE CODE	JACK WU	2017-09-28
C	UPDATE DATE CODE	KELLY	2018-10-17

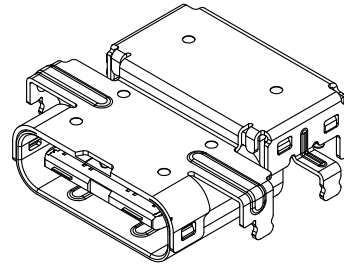
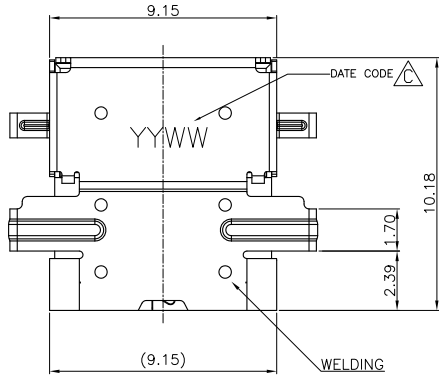

3D VIEW

NOTES:

- MATERIAL:
 - OUTSIDE SHELL: SUS301R-1/2H T=0.20mm
 - INNER SHELL: SUS301R-1/2H T=0.20mm
 - SIGNAL: SUS301R-H T=0.10mm
 - RFI PAD: SUS301R-H T=0.08mm
 - HOUSING: LCP+30%G.F. UL94UL-0 BLACK
 - TERMINAL: C19400-H T=0.10mm
- PLATING:
 - TERMINAL: Au ON MATING AREA, MATTE Sn 60~150u" ON SOLDERING AREA, 80~150u" NICKEL UNDER PLATING OVERALL
 - SHELL: NICKEL PLATED 60u"MIN.
- ELECTRICAL CHARACTERISTICS:
 - CURRENT RATING: 5.0 A
VOLTAGE RATING: 20.0 V
 - LLCR: VBUS& GND PINS: 40mΩ/PIN MAX
OTHER PINS : 40mΩ/PIN MAX
CHANGE OF ALL PINS: 10mΩ
 - INSULATION RESISTANCE: 100MΩ MIN.
- MECHANICAL CHARACTERISTICS:
 - INSERTION FORCE: 0.5~2.0kg.
 - WITHDRAWAL FORCE: 0.8~2.0kg.(INITIAL) 0.5~2.0kg.(AFTER LIFE TEST)
- LIFE TEST: 10000 CYCLES MIN
- P/N: UTC-005-1R24HX

PLATING OF CONTACT AREA
G: GOLD FLASH
6: 30u" Au

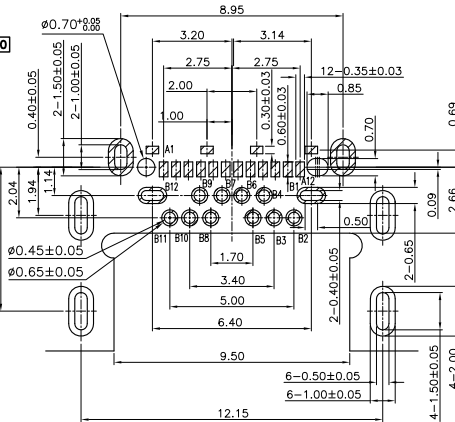
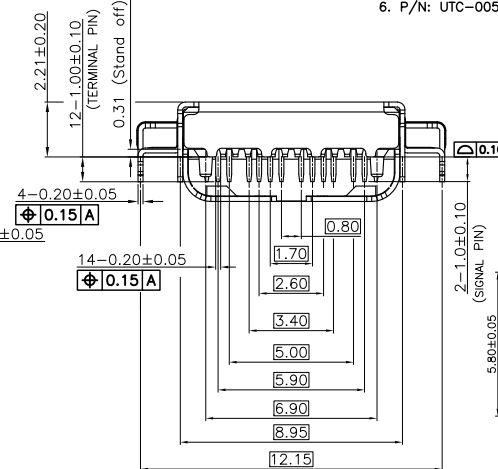
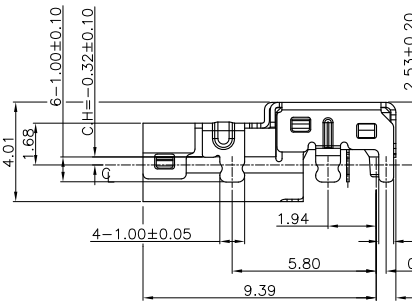
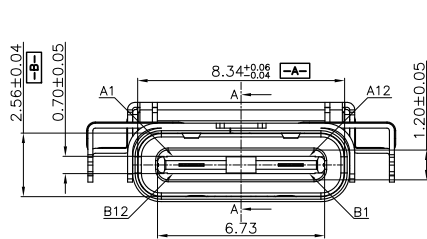

RECOMMENDED PCB LAYOUT(TOP VIEW)
(TOLERANCE=±0.05mm)

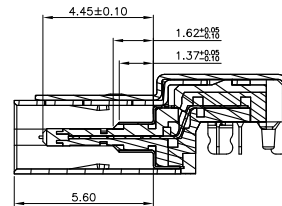
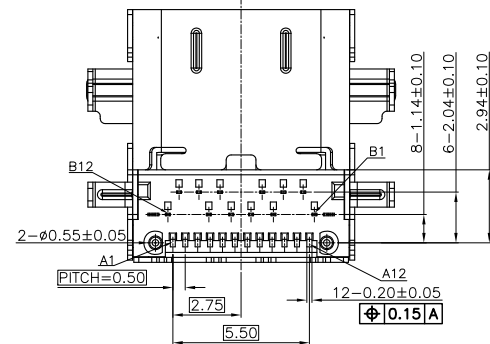

Section A-A

GENERAL TOLERANCES (OTHERWISE SPECIFIED)		SCALE NONE	DESIGN UNITS MILIMETER				
4 PLS	±	DRAWN BY KELLY	DATE 2018-10-17		TITLE		
3 PLS	± 0.10	CHECKED BY	DATE	USB TYPE C RA HYBRID TYPE CH=-0.32mm H=2.21mm			
2 PLS	± 0.20	APPROVED BY	DATE				
1 PLS	± 0.30						
ANGLES	± °	DRAWING NO. SD-UTC005-001	PART NO. UTC-005-1R24HX				
QUALITY SYMBOLS		THIS DRAWING CONTAINS INFORMATION THAT IS PROPRIETARY TO VITECK CORP., LTD AND SHOULD NOT BE USED WITHOUT WRITTEN PERMISSION		THIRD ANGLE PROJECTION	DWG REV. C	SHEET NO. 1 OF 1	SIZE

HALOGEN FREE

REVISIONS			
REV	DESCRIPTION	DWN	DATE
A	RFQ-17-041	JACK WU	2017-09-28

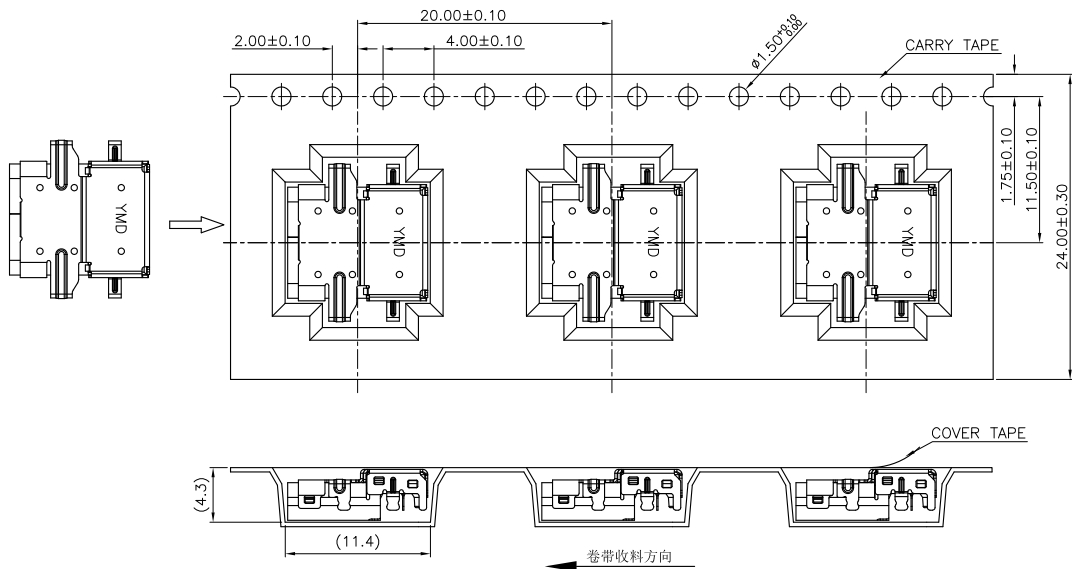
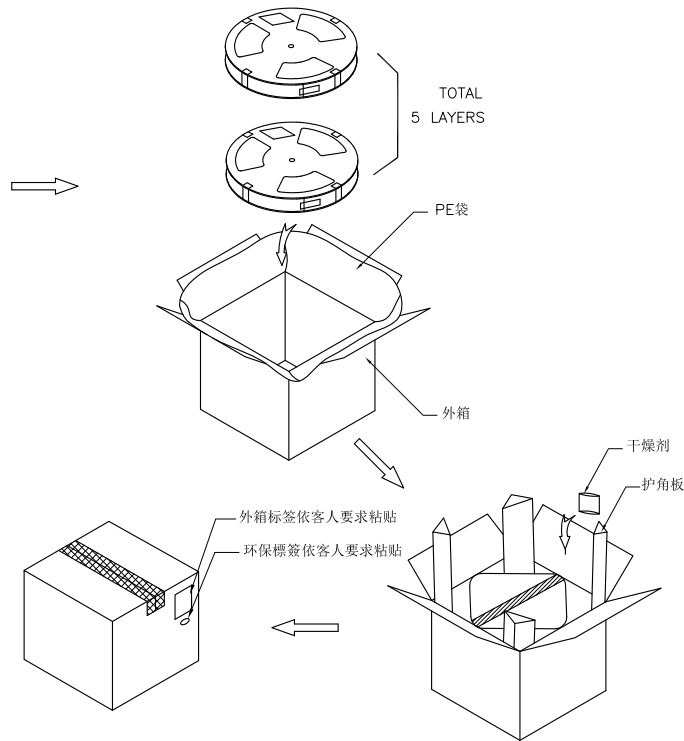
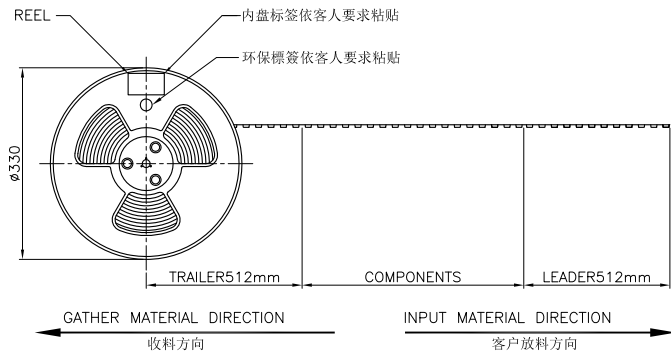

PARTS PER SHIPPING CARTON	PARTS PER REEL (S.P.Q.)	TOTAL REELS PER PRIMARY CARTON
3500 (PCS)	700 (PCS)	5

Notes:

1. 每卷卷带的开始端留32PCS空格不装产品，以实际包装数量装满，结束端预留空出不装产品；
2. 卷带用自封胶带封口，1个卷盘放置700PCS产品；
3. 再绕一圈保护带，保护带最后重量约50mm，每个卷盘须贴的标签依客人要求粘贴；
4. 将PE袋套入外箱后，将5盘装好产品的卷盘依次放入纸箱，并在纸箱封角各放入干燥剂一袋；
5. 外箱外侧以胶带封口，每个外箱外侧图示位置贴的标签依客人要求粘贴；
6. COVER TAPE與CARRY TAPE剥离力：20g~120g；
剥离角度：165°~175°；剥离速度：250~300mm/min；
7. 包装数量：700PCS/REEL，5REEL/CARTON，共3500PCS/CARTON；
8. 此部品必须符合无卤指令要求。

GENERAL TOLERANCES (OTHERWISE SPECIFIED)		SCALE	DESIGN UNITS	
4 PLS	±	NONE	MILIMETER	
3 PLS	±	DRAWN BY	DATE	TITLE USB TYPE C RA HYBRID TYPE CH=-0.32mm H=2.21mm PACKING
2 PLS	±	JACK WU	2017-09-28	
1 PLS	±	CHECKED BY	DATE	
ANGLES		APPROVED BY		PART NO. UTC-005-1R24HX
QUALITY SYMBOLS		DRAWING NO.		
THIS DRAWING CONTAINS INFORMATION THAT IS PROPRIETARY TO VITECK CORP., LTD AND SHOULD NOT BE USED WITHOUT WRITTEN PERMISSION		PK-UTC005-001		THIRD ANGLE PROJECTION
		DWG REV. A		SHEET NO. 1 OF 1
				SIZE