

7

6

5

4

3

2

1

REVISIONS			
REV	DESCRIPTION	DWN	DATE
1	PRE	ALDD	2016-03-16

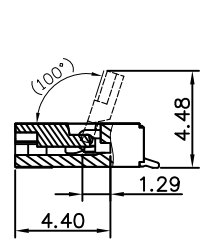
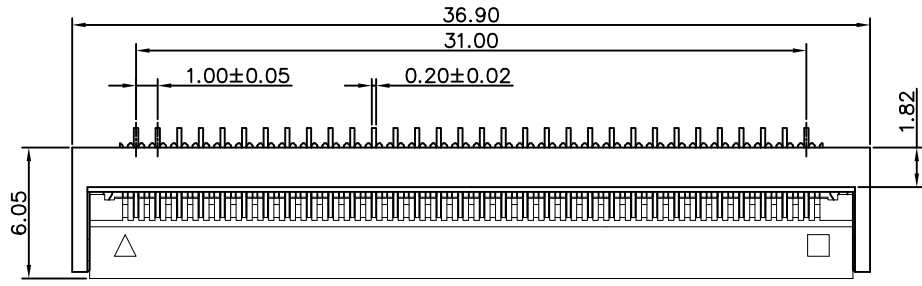

- NOTES:
- MATERIAL:
 - HOUSING: ENGINEERING PLASTIC(LCP),UL94V-0, COLOR: NATURAL.(WHITE)
 - ACTUATOR: ENGINEERING PLASTIC(LCP),UL94V-0, COLOR: BLACK.
 - CONTACTS: COPPER ALLOY
 - FITTING NAIL: COPPER ALLOY
 - PLATING:
 - CONTACTS: Au PLATING IN CONTACT AREA(SEE NOTES 5) GLDD FLASH(Au) IN SOLDER AREA. 50u*MIN. NICKEL UNDERPLATING OVERALL.
 - FITTING NAIL: 100u*MIN. MATTE-TIN ON SOLDER AREA, 50u*MIN. NICKEL UNDERPLATING OVERALL.
 - ROSH AND HALOGEN FREE COMPLIANT.
 - MEET LEAD FREE PROCESS(IR REFLOW 260 DEGREE CENTIGRADE).
 - PART NUMBER: FPC-030-14XXHX

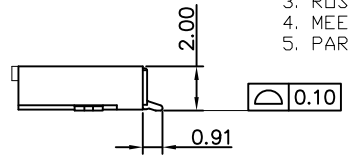
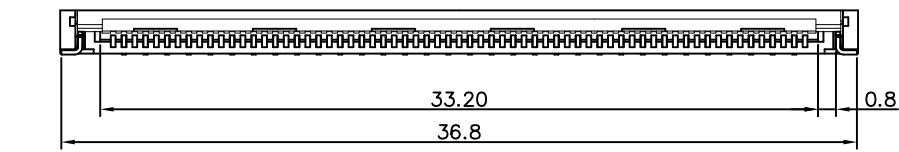

AU PLATING:
G: GLDD FLASH
NO. OF CONTACTS:
32

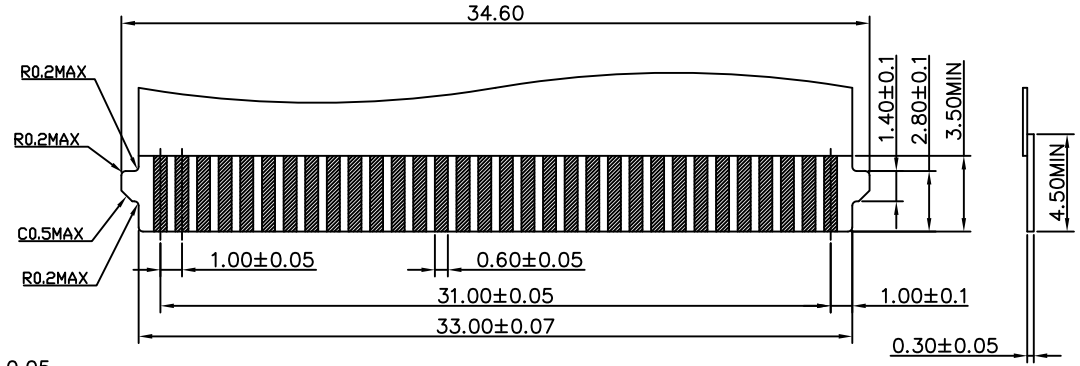
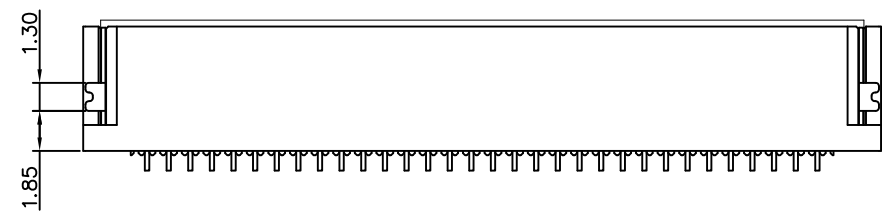

APPLICABLE F.P.C DIMENSION (REF.)

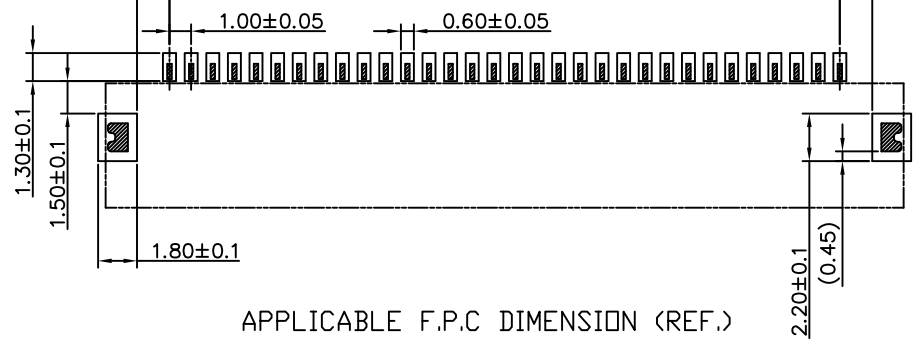
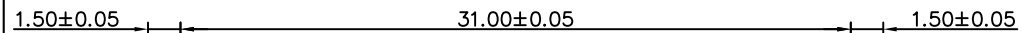

APPLICABLE F.P.C DIMENSION (REF.)

GENERAL TOLERANCES (OTHERWISE SPECIFIED)	SCALE 1 : 1	DESIGN UNITS MILIMETER	<p>VITECK CO., LTD.</p> <p>TITLE 1.00 PITCH EASY-ON RA SMT BOTTOM CONTACT H=2.00mm</p> <p>PART NO. FPC-030-SERIES</p>
4 PLS ±	DRAWN BY ALDD	DATE 2015-10-22	
3 PLS ±	CHECKED BY	DATE	
2 PLS ± 0.15	APPROVED BY	DATE	
1 PLS ± 0.25	DRAWING NO. SD-FPC030-001		
ANGLES ± °	THIS DRAWING CONTAINS INFORMATION THAT IS PROPRIETARY TO VITECK CORP., LTD AND SHOULD NOT BE USED WITHOUT WRITTEN PERMISSION		THIRD ANGLE PROJECTION
QUALITY SYMBOLS ▽=0	DWG. REV. 1	SHEET NO. 1 OF 1	SIZE

E

D

C

B

A

E

D

C

B

A

7

6

5

4

3

2

1

7

6

5

4

3

2

1

REVISIONS			
REV	DESCRIPTION	DWN	DATE
1	PRE	ALDO	2016/03/16

NO. OF CONTACTS	PACKING			Carton
	REEL	REEL/CARTON	QUANTITY(PCS)	
32PIN	1500	5	7500	370mm(L)X380mm(W)X340mm(H)

STANDARD PACKAGE: 2000 PCS / REEL

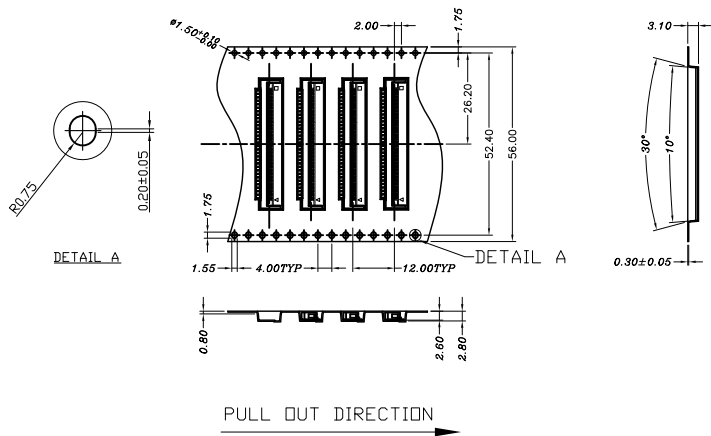
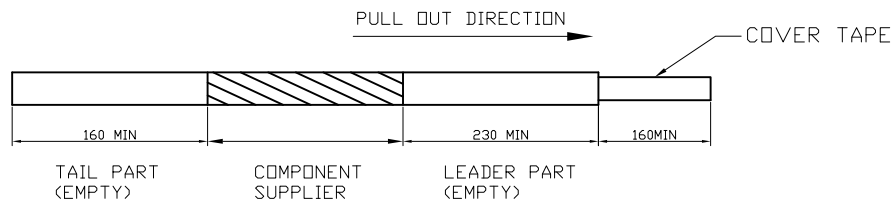
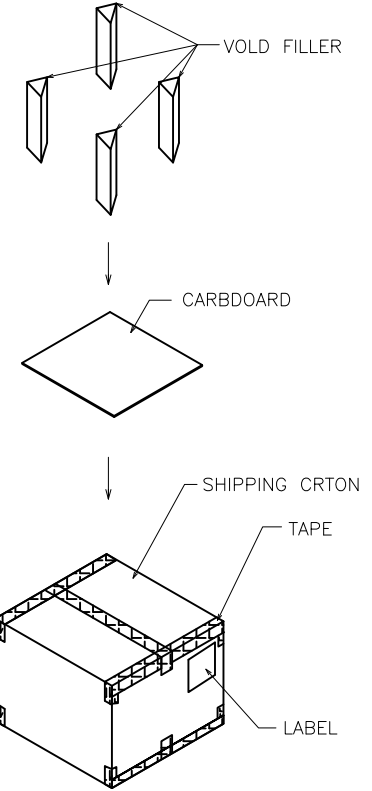
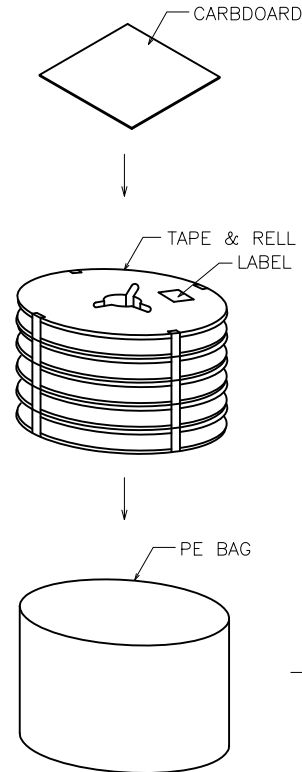
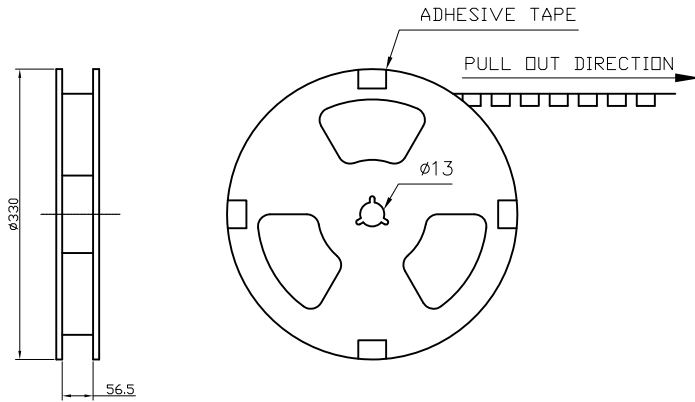

GENERAL TOLERANCES (OTHERWISE SPECIFIED)	SCALE NONE	DESIGN UNITS MILIMETER
4 PLS ±	DRAWN BY ALDO	DATE 2015-11-18
3 PLS ±	CHECKED BY	DATE
2 PLS ± 0.25	APPROVED BY	DATE
1 PLS ± 0.25		
ANGLES ± °	DRAWING NO. PK-FPC030-001	PART NO. FPC-030 Series
QUALITY SYMBOLS $\nabla \sqrt{0}$		

VITECK CO., LTD.

TITLE
1.00 PITCH EASY-ON RA SMT
BOTTOM CONTACT H=2.00mm

THIS DRAWING CONTAINS INFORMATION THAT IS PROPRIETARY TO VITECK CORP., LTD AND SHOULD NOT BE USED WITHOUT WRITTEN PERMISSION

THIRD ANGLE PROJECTION

DWG REV. 1	SHEET NO. 1 OF 1	SIZE
------------	------------------	------

6

5

4

3

2

1