

7

6

5

4

3

2

1

REVISIONS			
REV	DESCRIPTION	DWN	DATE

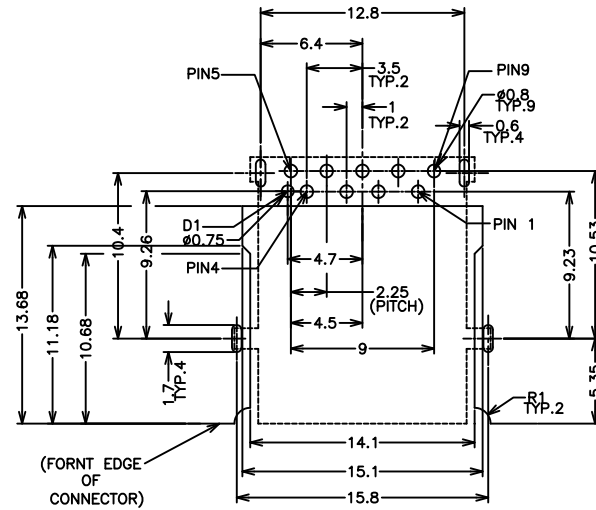
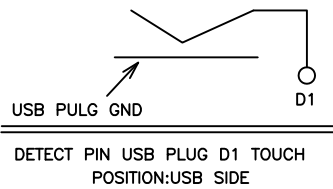
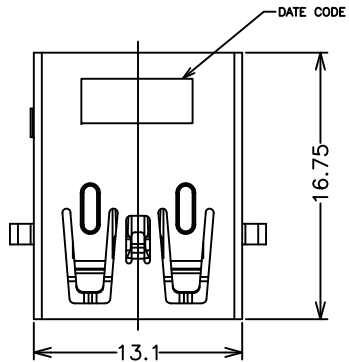

RECOMMEND P.C.BOARD LAYOUT T=1.20mm
PCB TOLERANCE:±0.05

- NOTES:
 1.MATERIAL:
 HOUSING: THERMOPLASTIC HIGH TEMP
 WITH 30%G/F UL94 V-0(LCP E130I),COLOR: BLACK
 USB2.0 CONTACT: PHOSPHOR BRONZE(C5191-H,THICKNESS=0.25mm)
 USB3.0 CONTACT: BRASS(C2680-H,THICKNESS=0.2mm)
 DETECT PIN: PHOSPHOR BRONZE(C5210-EH,THICKNESS=0.20mm)
 SHELL:STAINLESS(SUS304-H,THICKNESS=0.3mm)
 2.FINISH:
 CONTACT: GOLD FLASH PLATING ON CONTACT AREA
 100u" MIN. MATTE TIN PLATING ON SOLDERTAILS
 50u" MIN.NICKEL UNDERPLATING OVER ALL
 SHELL: 50u" MIN.NICKEL UNDERPLATING OVER ALL
 3.DATE CODE: YY (YEAR), MM(MONTH) .DD (DATE)
 4.ROHS AND HALOGEN FREE COMPLIANT

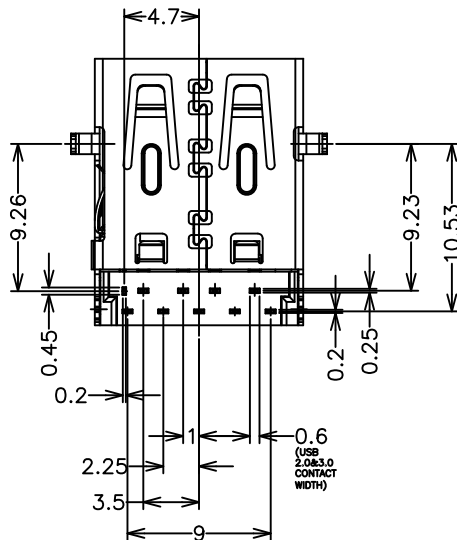
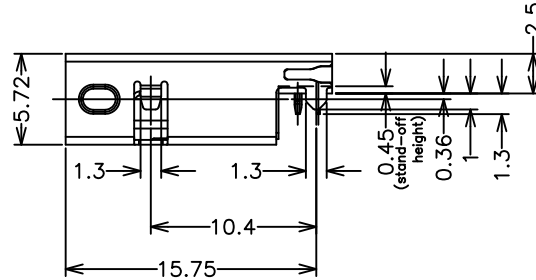
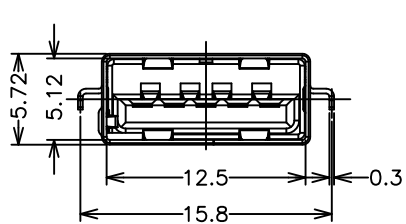

PIN DEFINITION

USB2.0		USB3.0	
NAME	TYPE	NAME	TYPE
P1	VBUS	P5	SSRX-
P2	D-	P6	SSRX+
P3	D+	P7	GND
P4	GND	P8	SSTX-
D1	DP	P9	SSTX+

GENERAL TOLERANCES (OTHERWISE SPECIFIED)	SCALE NONE	DESIGN UNITS MILIMETER	
4 PLS ±	DRAWN BY LIN	DATE 2013-07-03	
3 PLS ±	CHECKED BY	DATE	TITLE
2 PLS ± 0.15	APPROVED BY	DATE	USB3.0 A TYPE RECEPTACLE REVERSE RA
1 PLS ± 0.25	DRAWING NO. SD-A0041-001	PART NO. A0041-00001	DIP C/H=0.36mm With DETECT PIN
ANGLES ± °	THIS DRAWING CONTAINS INFORMATION THAT IS PROPRIETARY TO VITECK CORP, LTD AND SHOULD NOT BE USED WITHOUT WRITTEN PERMISSION	THIRD ANGLE PROJECTION	DWG REV. A
QUALITY SYMBOLS			SHEET NO. 1 OF 1
			SIZE

6

5

4

3

2

1

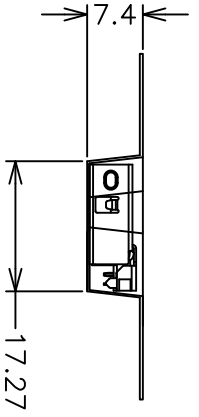
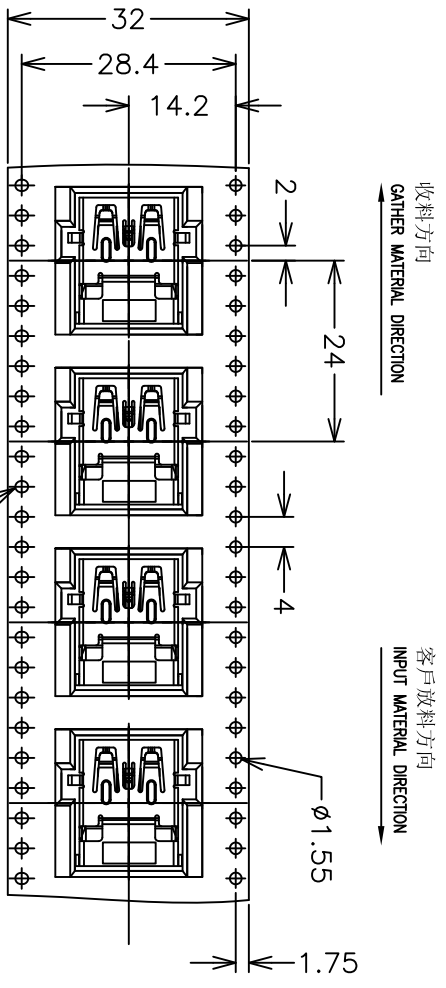
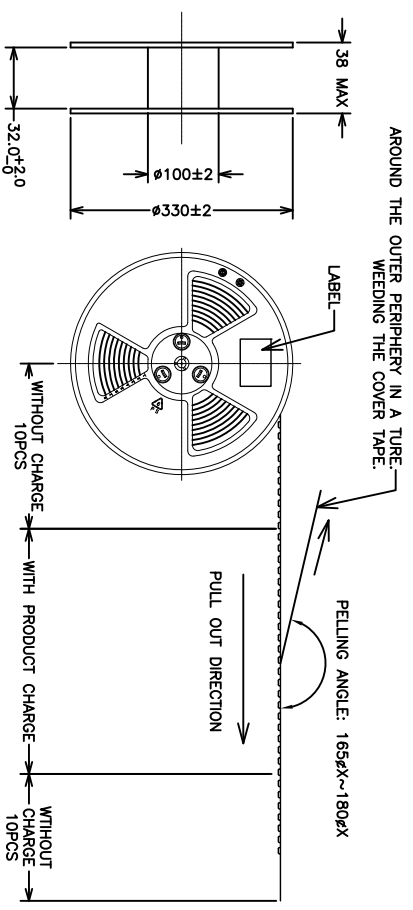

PRODUCT P/N	A0041-00001	PARTS PER SHIPPING CARTON	2100(PCS)	PARTS PER REEL (S.P.Q.)	300(PCS)	TOTAL REELS PER SHIPPING CARTON	7
-------------	-------------	---------------------------	-----------	-------------------------	----------	---------------------------------	---

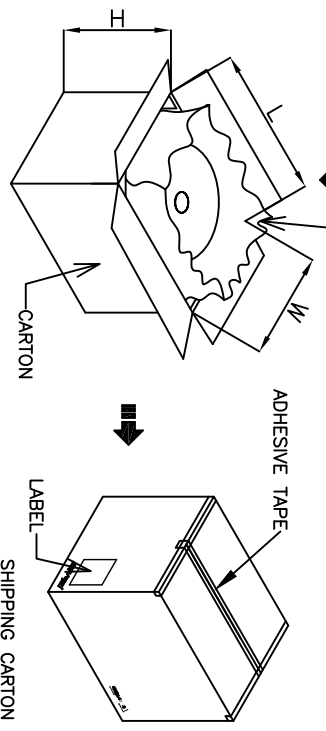

REVISIONS		
REV	DESCRIPTION	DATE

GENERAL TOLERANCES (OTHERWISE SPECIFIED)	SCALE	DESIGN UNITS	VITECK CO., LTD.	TITLE
4 PLS ± 0.25	NONE	MILIMETER		USB3.0 A TYPE RECEPTACLE REVERSE RA
3 PLS ± 0.25	DRAWN BY	DATE		DIP C/H=0.36mm With DETECT PIN
2 PLS ± 0.25	CHECKED BY	DATE		
1 PLS ± 0.25	APPROVED BY	DATE		
ANGLES ± °	DRAWING NO.	PART NO.	A0041-00001	
QUALITY SYMBOLS	SD-A0041-001			

THIS DRAWING CONTAINS INFORMATION THAT IS PROPRIETARY TO VITECK CORP. LTD AND SHOULD NOT BE USED WITHOUT WRITTEN PERMISSION