

Contact Number	Signal Name
PIN1	VEBUS
PIN2	D-
PIN3	D+
PIN4	GND
PIN5	SH4_SSRX-
PIN6	SH4_SSRX+
PIN7	GND_DRAIN
PIN8	SH4_SSTX-
PIN9	SH4_SSTX+
Shell	Shield

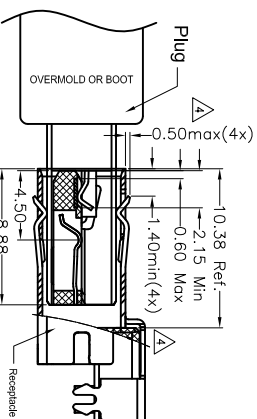
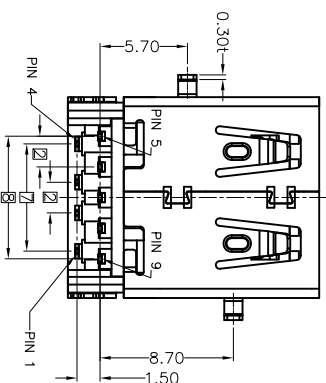
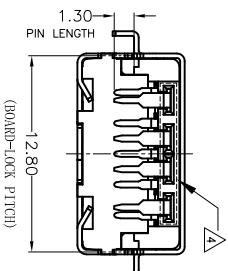
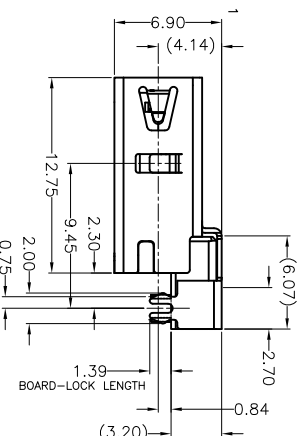
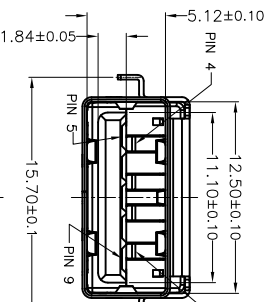
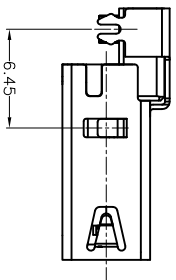
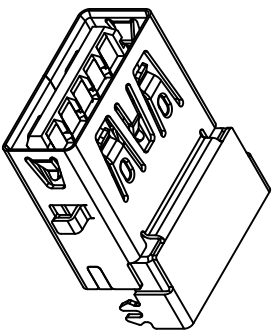
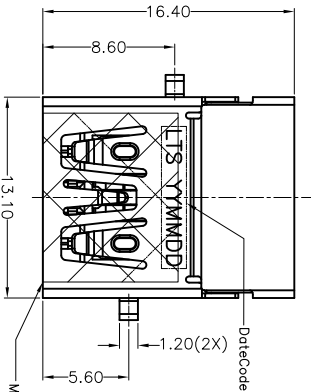

REVISIONS			
REV	DESCRIPTION	DWN	DATE
3	PROPOSAL	MAX	2014-07-10
4	ADD DIMENSION	JACK WU	2017-09-01

- NOTE:
- MATERIAL:
 - 1.1 HOUSING: HIGH TEMP. THERMAL PLASTIC, GLASS FIBER FILLED, UL94V-0, COLOR:SEE EXTENSION NO. TABLE.
 - 1.2 CONTACT: COPPER ALLOY.
 - 1.3 SHELL: STAINLESS STEEL.
 - FINISH:
 - 2.1 CONTACT:
 - AU PLATING ON CONTACT AREA ,
 - 50U"MIN. MATTE TIN PLATING ON SOLDER AREA,
 - 50U"MIN. NICKEL UNDERPLATING OVERALL.
 - 2.2 SHELL: 80U"MIN. NICKEL PLATING OVERALL.

3. DATE CODE: YY (YEAR), MM (MONTH), DD (DATE)
4. ROHS AND HALOGEN FREE COMPLIANT
5. PART LEGEND: USB-009-XR09HX

EXTENSION NO. SEE TABLE.

AU PLATING OF CONTACT AREA
 G : GOLD FLASH
 1 : Au 5u"
 6 : Au 30u"

EXTENSION No. TABLE			
NO.	HOUSING COLOR	MYLAR	
1	BLACK	ND	
2	BLACK	YES	
3	BLUE (GRANTONE 300C)	ND	
4	BLUE (GRANTONE 300C)	YES	

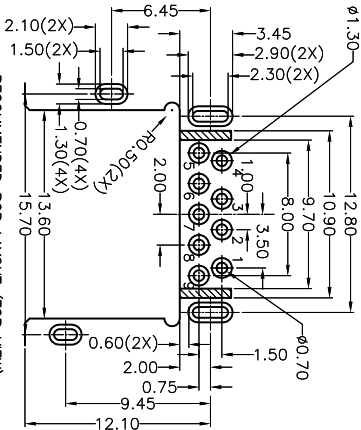

RECOMMENDED PCB LAYOUT (TOP VIEW)
 GENERAL TOLERANCES:±0.06 (≠1.2)

GENERAL TOLERANCES (OTHERWISE SPECIFIED)	SCALE	DESIGN UNITS
Mm	1 : 1	MILIMETER
4 PLS ±	DRAWN BY MAX	DATE 2014-07-10
3 PLS ±	CHECKED BY	
2 PLS ± 0.20	APPROVED BY	DATE
1 PLS ± 0.25		
ANGLES ± °		
QUALITY SYMBOLS	DRAWING NO. SD-USSB009-001	

VITECK CO., LTD.			
TITLE	PART NO.	DWG REV.	SHEET NO.
USB3.0 A TYPE RECEPTACLE REVERSE RIGHT ANGLE DIP C/H=0.84mm	USB-009 SERIES	4	1 OF 1



THIRD ANGLE PROJECTION



VITECK CO., LTD.

PRODUCT P/N	PARTS PER SHIPPING CARTON	PARTS PER REEL (S.P.Q.)	TOTAL REELS PER SHIPPING CARTON
USB-009 SERIES	3500(PCS)	350(PCS)	10

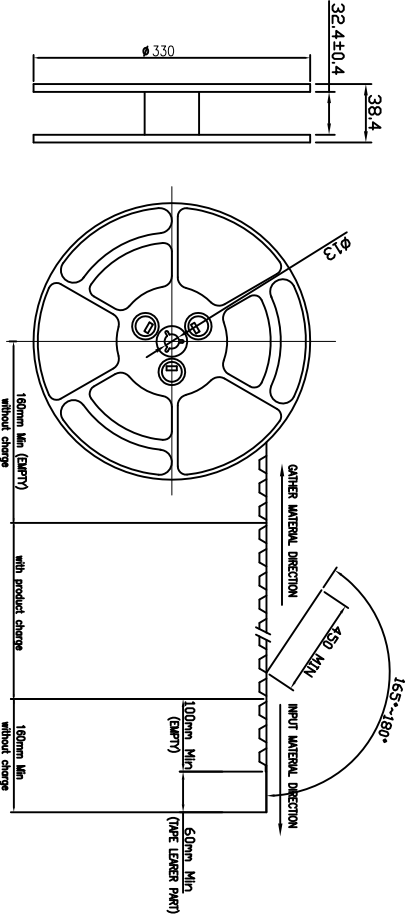

REVISIONS			
REV	DESCRIPTION	DWN	DATE
1	PROPOSAL	MAX	2014-04-28

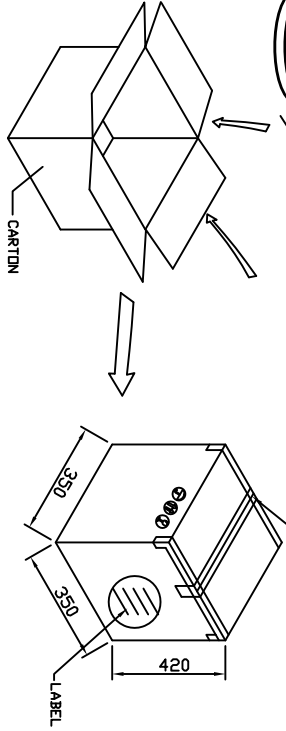
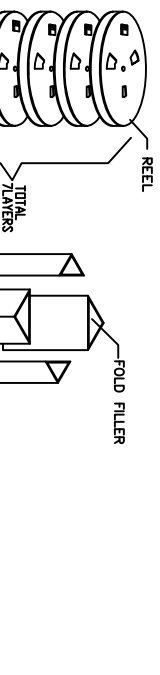
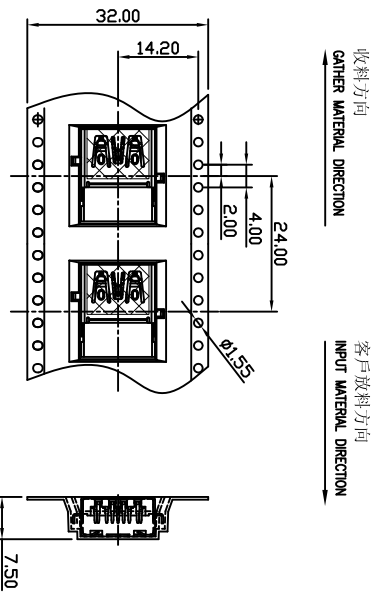

GENERAL TOLERANCES (OTHERWISE SPECIFIED)	SCALE	DESIGN UNITS
Mm	NONE	MILIMETER

4 PLS ±	DRAWN BY	DATE
3 PLS ±	MAX	2014-04-28
2 PLS ± 0.25	CHECKED BY	DATE
1 PLS ± 0.25	APPROVED BY	DATE

QUALITY SYMBOLS	DRAWING NO.	PART NO.
∇ $\neq 0$	PK-USB009-001	USB-009 SERIES

1 COVER TAPE PEELING FORCE:

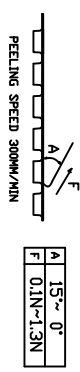

2 PART DIMENSIONS MEET EIA-481-2-A REQUIREMENT

VITECK CO., LTD.

USB3.0 A TYPE RECEPTACLE REVERSE
RIGHT ANGLE DIP C/H=0.84mm

THIRD ANGLE PROJECTION	DWG REV.	SHEET NO.	SIZE
	1	1 OF 1	

THIS DRAWING CONTAINS INFORMATION THAT IS PROPRIETARY TO VITECK CORP. LTD AND SHOULD NOT BE USED WITHOUT WRITTEN PERMISSION